

Make a Tibetan Prayer Wheel out of cardboard



Assembly Procedure: Prayer Wheel

Tools and Materials:

- Scissors to cut paper and cardboard
- Cellophane Tape
- Glue
- 1 round pencil, as long as possible, sharpened on one end
- Cardboard – About 1 square foot
- 1 sheet of paper
- 1 piece of string approximately 8 inches long
- A small amount of clay as a weight

Step 1:

Decorate Part 1. (wheel base) This is the bottom of the prayer wheel. Cut it out and use it to trace two circles in cardboard.

-Cut those circles out and glue them together. Alternating the direction of the corrugations.

-Use the sharpened pencil to pierce the center hole the stack of two circles and wiggle the pencil so it rotates very easily in the hole. Make it so that when you spin it it spins freely on it's own.

Step 2:

Cut out part 2 (center column)

Use it as a template to cut out a piece of cardboard (Note the direction of the corrugations. It is important.

Peel off the top layer of kraft paper and set it aside for later use.

Wrap it around your pencil with the paper side against the pencil. (The corrugations outward and showing) and tape it. This should be a loose fit and should rotate easily around the pencil.

Step 3:

Keep it on the pencil and slide it down into the prayer wheel base. The blunt or eraser end of the pencil should go into the hole, not the pointed end. Glue this center column securely to the prayer wheel base. It's important to use the pencil this way. It will keep everything very straight. Insure the glue does not glue the pencil to anything. It should rotate freely.

Once it is set in place you can remove the pencil. And once it dries you should be able to drop the pencil into it and it will fall right through without stopping or jamming.

Step 4

The Wheel wall (part 3)

Use it as a template to cut out a piece of cardboard, note the direction of the corrugations.

Remove one layer of kraft paper off the cardboard.

Wrap it around the part 1 stack and glue it in place.

Note that you should cut away part of the corrugations (About ½ inch) on one end of the part to overlap it for a smooth surface around the wheel.

Step 5

Cut out part 4 from the template (top cover)

Use it to trace onto cardboard and cut that circle out

Use your pencil to pierce the hole in the center

Note: Do not wiggle the pencil. You want this part to be a snug fit on the cardboard and not easy to rotate

Step 6:

Cut out part 5 (Inner Handle)

-Use this template to trace out a cardboard part. Noting the direction of the corrugations.

-Peel the top layer of kraft paper off the cardboard

-Wrap this part around your pencil tightly, with the corrugations inward. Tape it in place. Add some glue to it. To make it a tight and firm fit that does not rotate and the pencil will not slip out.

NOTE: the flat end, or eraser end, of the pencil should extend outside the cardboard by 3 inches

Step 7:

Cut out part 6 (Outer handle)

Transfer that pattern to cardboard and cut it out

Remove the top sheet of kraft paper.

Wrap it around the inner handle. Make it even with the bottom of the handle (the end without the pencil extended)

Step 8:

Cut out part 7 (Anchor)

Use this as a template and put it on one of your scraps of kraft paper, trace it and cut it out. Fold it in half and pierce a hole at the dot.

Glue it as shown to the side of the prayer wheel.

Step 9: Cut out the weight pouch (part8)

Fold it into shape and place some weight inside it. This weight can be clay or coins or some other object.

Tie the string to it. Then tie the other end of the string to the anchor on the prayer wheel.

Step 10: Write your message or prayer on part 9. Cut it out, curl it up a bit and place it in your prayer wheel. Place the cover on your prayer wheel and have fun spinning it!

DIRECTION OF CORRUGATIONS

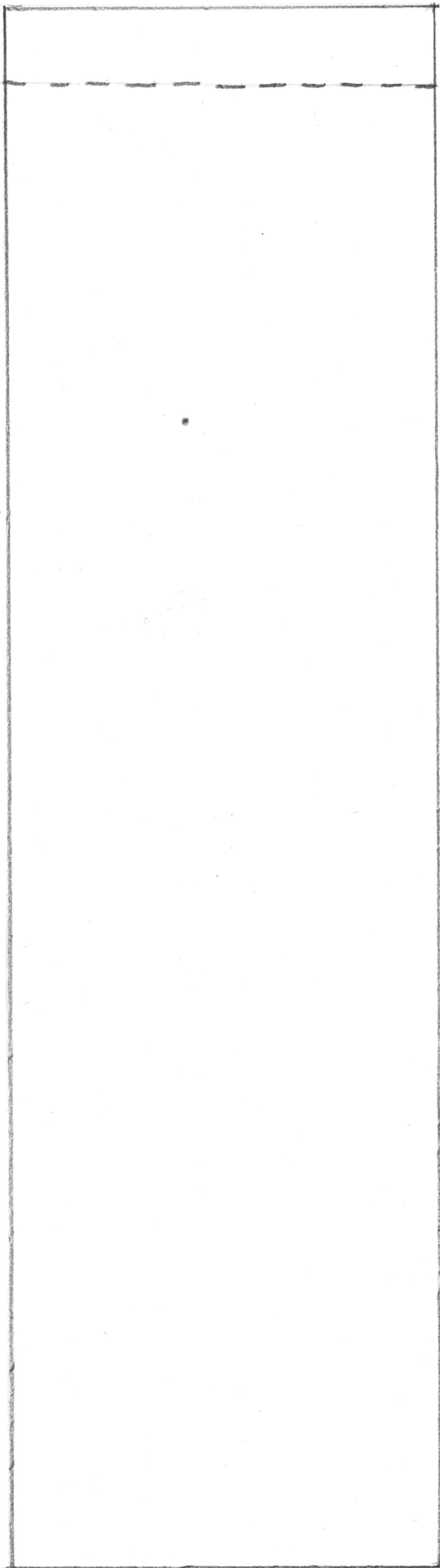

PART 3 (WHEEL WALL)

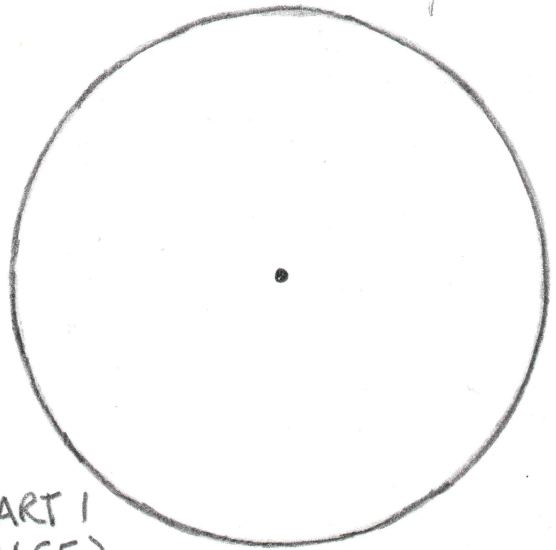

PART 1 (BASE)

PART 2 (CENTER COLUMN)

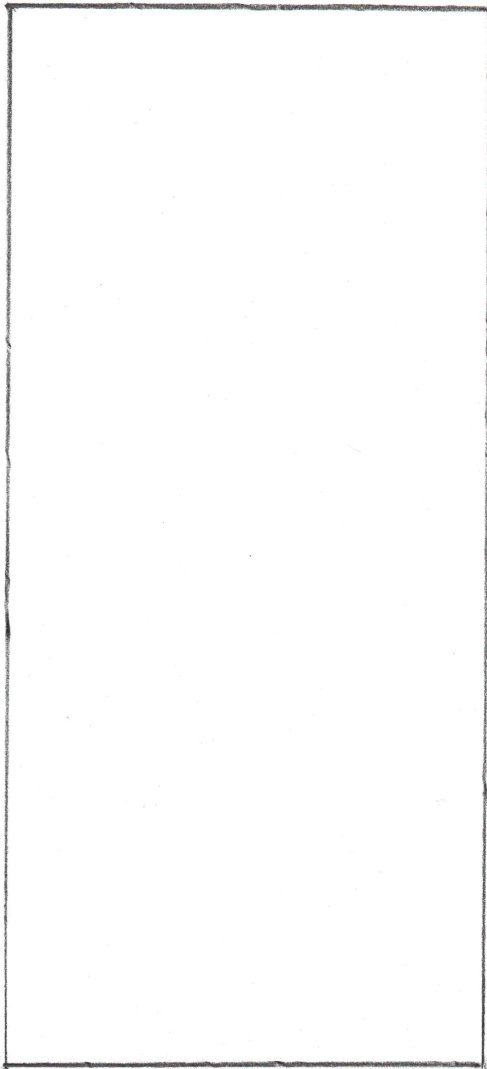

DIRECTION OF CORRUGATIONS

PART 7 (ANCHOR)

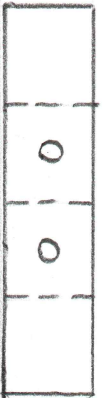

PART 4
(TOP COVER)

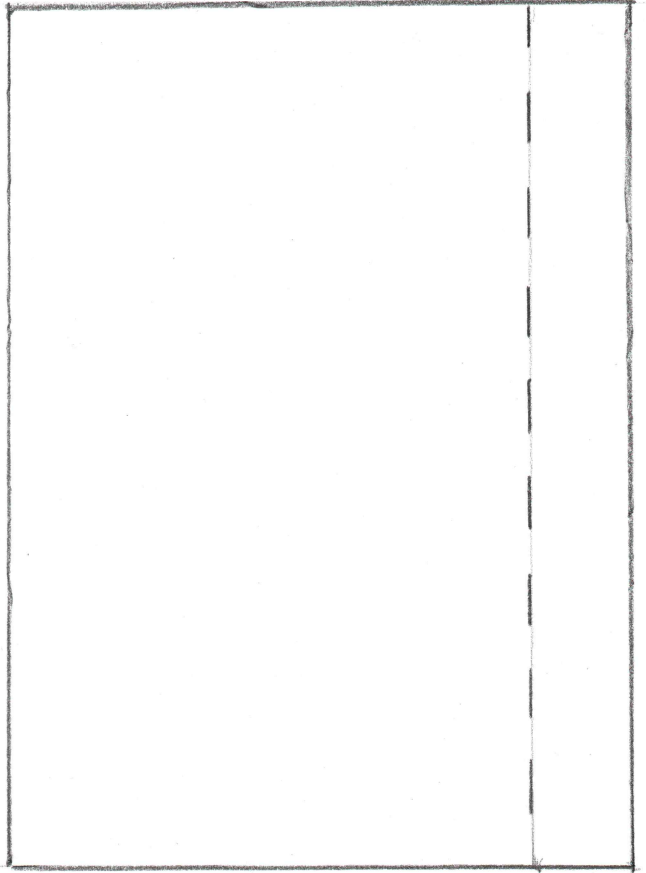
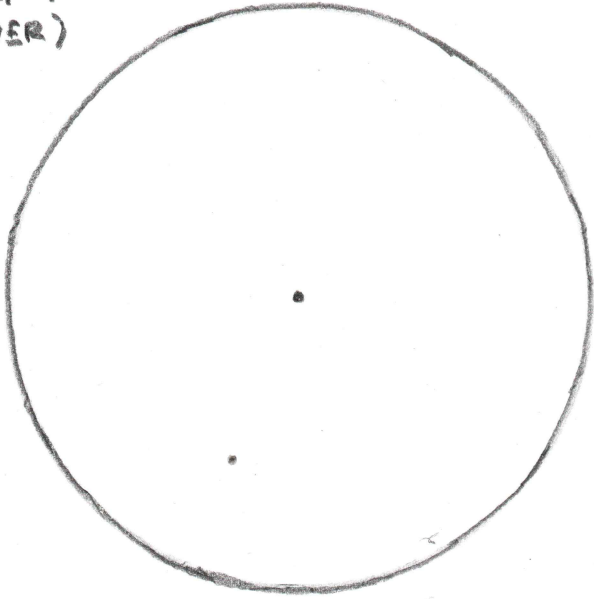

PART 5
(INNER HANDLE)

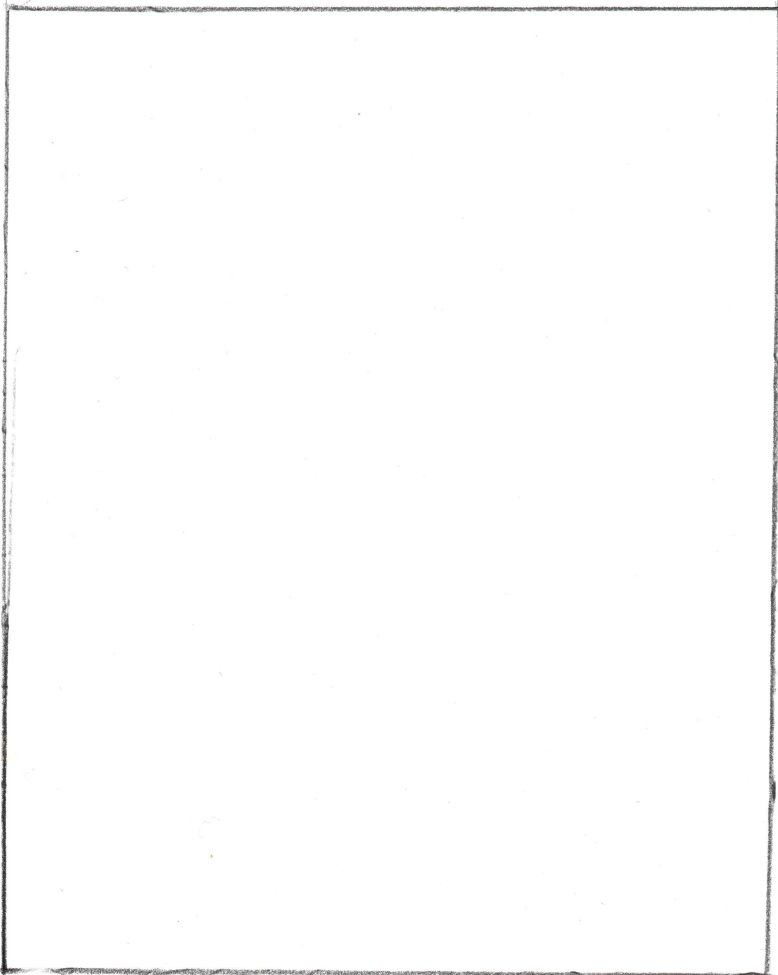

PART 6
(OUTER HANDLE)

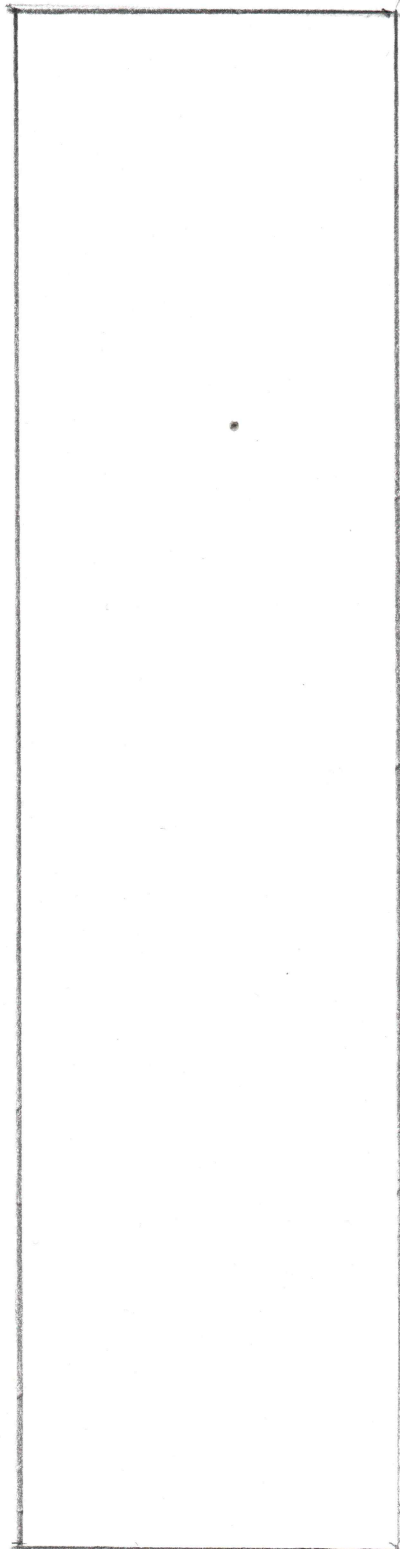

PART 8
(PRAYER SCROLL)

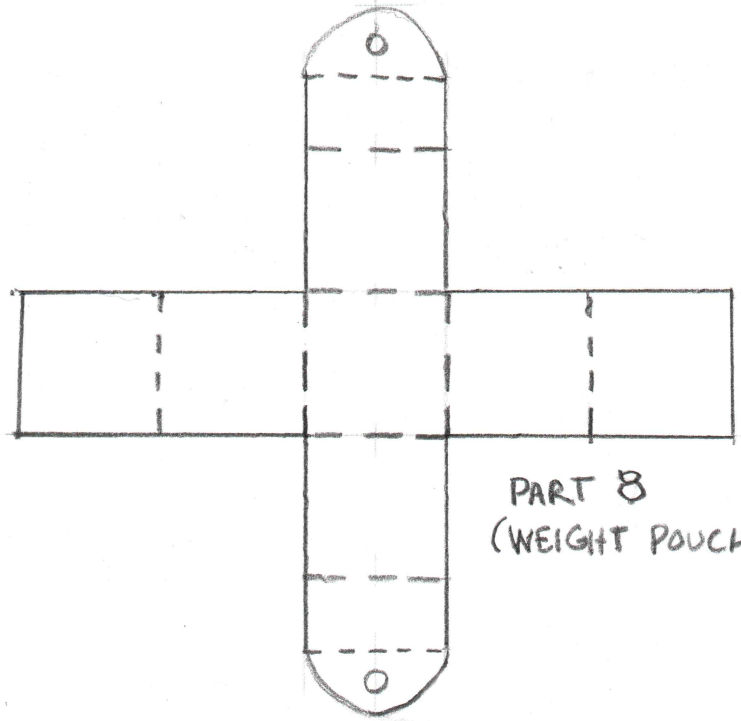

PART 8
(WEIGHT POUCH)

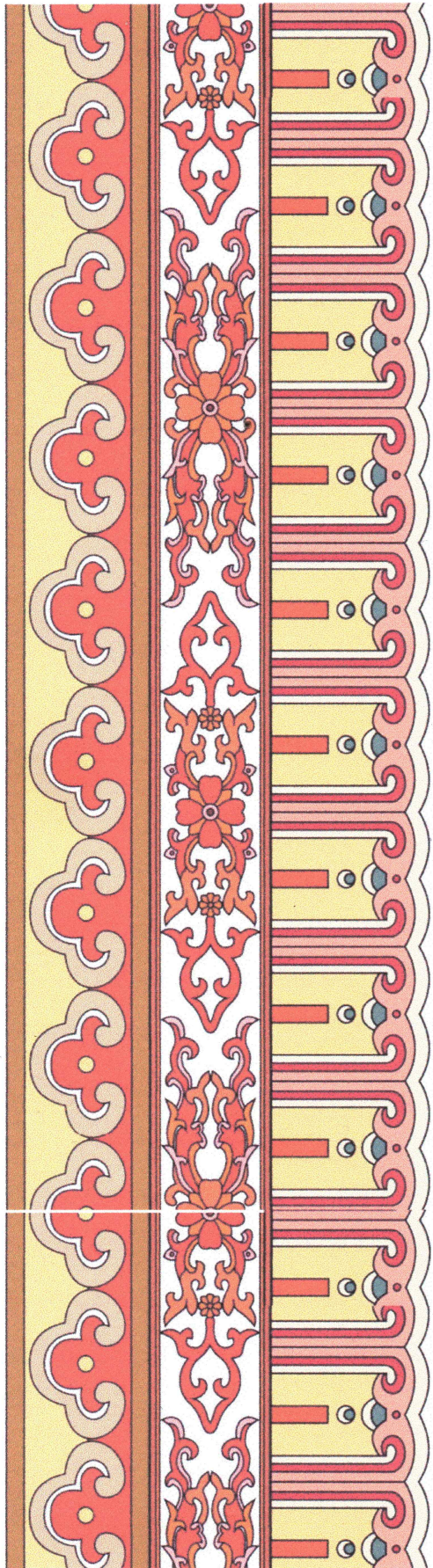

Top Cover



Wheel

Handle

